

speak easy

version 14.01.2014

Ute Wassermann - voice, birdwhistles (*v1*)

Phil Minton - voice (*v2*)

Martin Blume - drums, percussion (*dr/perc*)

Thomas Lehn - analogue synthesizer (*syn*)

I. Stage Set-Up

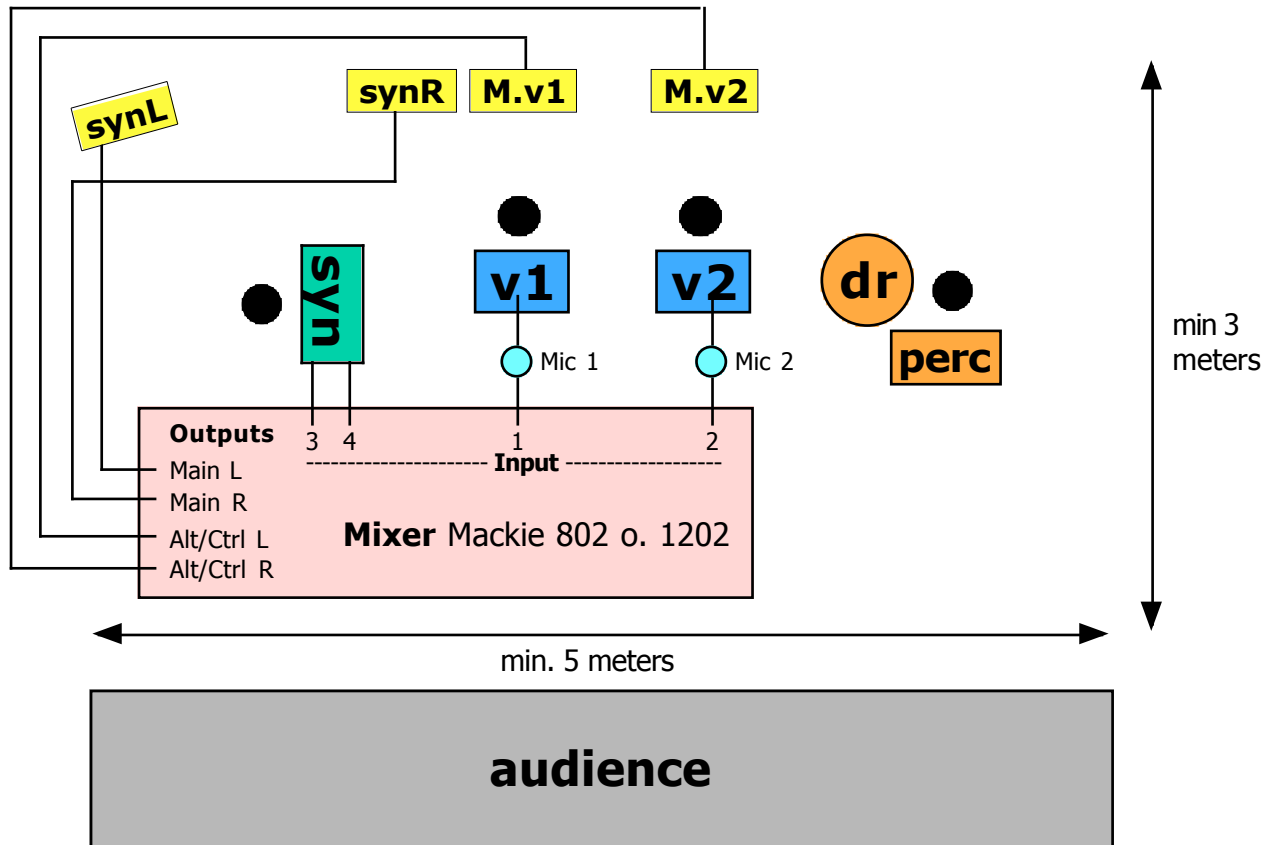

II. Technical Rider

- 4 speakers**, active or passive monitors (*synL*, *synR*, *M.v1*, *M.v2*) on stands/columns/table/chair. Required are **four independent channels(!)**: 2 for the 2 vocalists (*M.v1* und *M.v2*) and 2 for the stereo synthesizer (*synL* und *synR*). Ideally the 4 speakers are activemonitore with XLR-inputs.
- 2 vocal-microphones** on stands (*Mic 1* & *Mic 2*) for *v1* and *v2*.
- 1 small mixing desk** with two independently controllable stereo outputs (for example stereo-main-outs and stereo alt- or ctrl-out (as f.e. the **Mackie 802** or **Mackie 1202**))
- cables**: 6 XLR (of which 4 best at least 10m long!)
- for Thomas Lehn
1 table/case/box, size ca.: H 40cm, W 35-40cm, L 90-110cm [for the synth]
1 table/case/box, size ca.: H 40cm [for the small mixing desk]
1 chair (best is a piano bench with variable height)
- for Martin Blume:
1 drum set including 1 **ride** cymbal, 1 **crash** cymbal and 1 **hi-hat**
1 table (for percussions instruments (*perc*)

Kontakt: Martin Blume, mail@martinblume.de, phone +49.231.8642360, mobil +49.151.15177339